

CS1316

16-Port PS/2-USB VGA KVM Switch



The CS1316 KVM switch allows access and control up to 256 computers from a single console (keyboard, mouse, and monitor). As many as 16 additional switches can be cascaded bringing the total number of connected computers to 256 computers that can be controlled from a single KVM console. The switch supports both USB and PS/2 connections for the console and computers.

Features

- One USB-PS/2 console controls 16 computers
- Cascade up to 2 levels - control up to 256 computers
- Dual Interface - supports computers with PS/2 or USB keyboards and mice
- Multiplatform support - Windows 2000/XP/Vista, Linux, Mac, and Sun
- Video DynaSync™ - Exclusive ATEN technology eliminates boot-up display problems and optimizes resolution when switching between ports
- Auto PS/2 and USB interface detection
- USB or PS/2 keyboard and mouse emulation - computers boot even when the console focus is elsewhere
- Superior video quality - up to 2048 x 1536; DDC2B
- Computer selection via front panel pushbuttons, hotkeys and multilingual on-screen display (OSD) menu
- Two level password security - only authorized users view and control computers; up to four users and an administrator with a separate profile for each
- Auto Scan feature for monitoring user-selected computers
- Hot pluggable - add or remove computers without having to power down the switch
- Buzzer on/off via hotkey and OSD
- Firmware upgradeable
- No software installation required
- Designed for desktop or rack mount (19" system rack, 1U)

Specifications

Computer Connections	
Direct	16
Maximum	256 (via Cascade)
Port Selection	OSD, Hotkey, Pushbutton
Connectors	
Console Ports	1 x SPHD-18 Male (Yellow)
Firmware Upgrade	1 x RJ-11 Female (Black)
Power	1 x DC Jack
KVM Ports	16 x SPHD-18 Female (Yellow)
Switches	
Ports	16 x Pushbutton
Firmware Upgrade	1 x Slide
LEDs	
Online	16 (Orange)
Selected	16 (Green)
Power	1 (Dark Green)
Emulation	
Keyboard / Mouse	PS/2, USB
Video	2048 x 1536; DDC2B
Scan Interval	1-255 Seconds
Power Consumption	DC5.3V:3.83W:26BTU/h Note: ● The measurement in Watts indicates the typical power consumption of the device with no external loading. ● The measurement in BTU/h indicates the power consumption of the device when it is fully loaded.
Environmental	
Operating Temperature	0-50°C
Storage Temperature	-20-60°C
Humidity	0-80% RH, Non-condensing
Physical Properties	
Housing	Metal
Weight	2.10 kg (4.63 lb)
Dimensions (L x W x H)	43.72 x 16.13 x 4.40 cm (17.21 x 6.35 x 1.73 in.)
Note	For some of rack mount products, please note that the standard physical dimensions of WxDxH are expressed using a LxWxH format.

Diagram

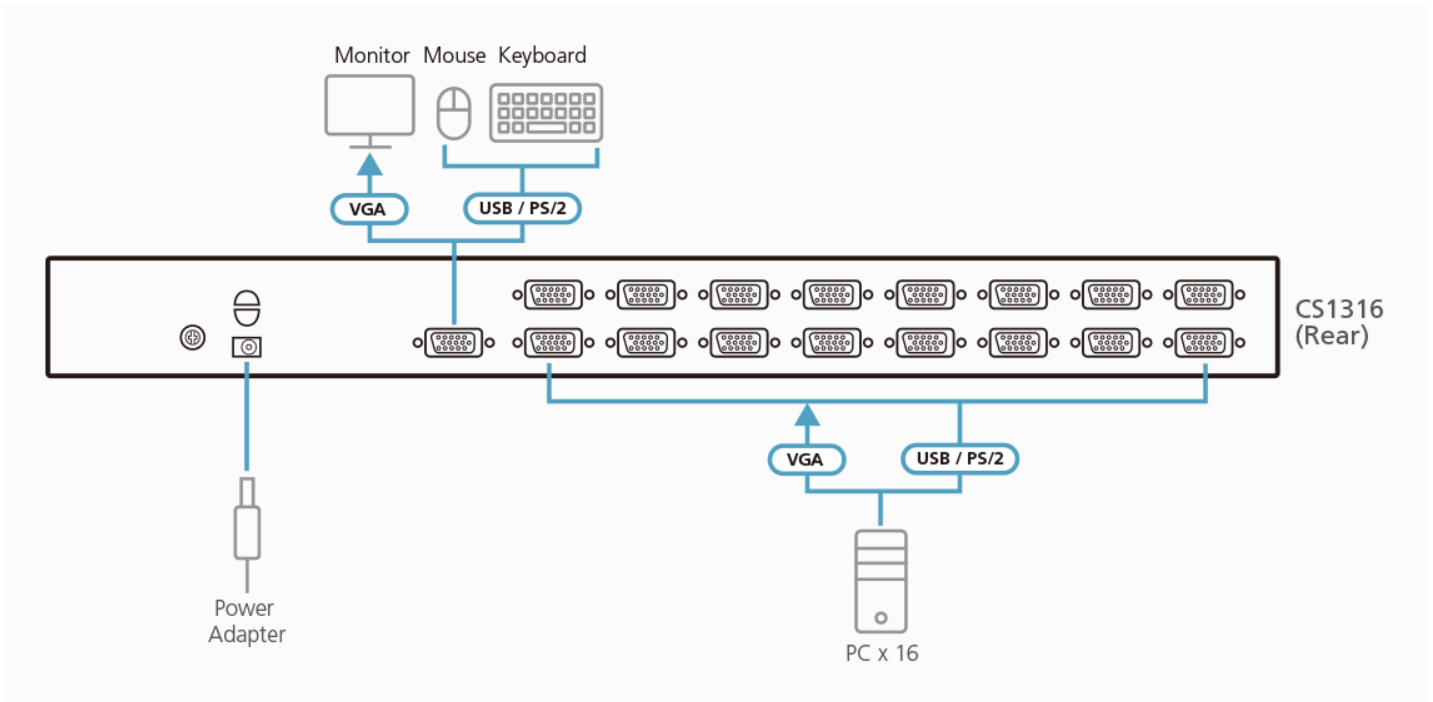

ATEN International Co., Ltd.

3F., No. 125, Sec. 2, Datong Rd., Sijhih District., New Taipei City 221, Taiwan
Phone: 886-2-8692-6789 Fax: 886-2-8692-6767
www.aten.com E-mail: marketing@aten.com



© Copyright 2015 ATEN® International Co., Ltd.
ATEN and the ATEN logo are trademarks of ATEN International Co., Ltd.
All rights reserved. All other trademarks are the property of their respective owners.