

PE6108AV

8-Outlet eco PDU



Ideal for Pro AV applications, the PE6108AV eco PDU is intelligent 1U rack PDU that contains 8 AC outlets in an IEC socket configuration. The unique design with detachable front panel makes it convenient when mounting with different Pro AV equipment in 19" racks at varying depths. In addition to remotely controlling individual outlets over the LAN, the front panel pushbuttons offer an extra option to control the outlets locally, allowing the flexibility to easily shutdown Pro AV equipment on the spot or from a remote location – for reduced power consumption. The outlets feature a sequential power-on function that ensures Pro AV systems are powered on safely. Furthermore, compatibility with the ATEN Control System and Control4 libraries allows the PE6108AV to integrate with any Pro AV equipment for full control of all devices without complex programming.

The PE6108AV is an optimal energy solution for data centers as well. With the combination of ATEN eco PDUs and [eco DC](#) Energy & DCIM Management Web GUI, a data center will be equipped with real-time monitoring, measurement, and analysis of energy consumption – with reports of power usage and PUE to meet the ISO 50001 requirements. These indices reflect the data center's energy usage and offer energy saving suggestions for optimizing energy use and reducing costs.

Features

• Connections

- Detachable front panel fits 19" racks with different depths
- Built-in 10/100 Mbit Ethernet Interface
- Supports TCP/IP, UDP, HTTP, HTTPS, SSL, DHCP, SMTP, ARP, NTP, DNS, Auto Sense, Ping, SNMP V1, V2, and V3, Telnet
- 2-level account/password security, IP/MAC filter, 128 bit SSL, RADIUS
- Browser access via IE, Firefox, Chrome, Safari, and more
- Easy integration with ATEN Control System and Control4 libraries
- Supports RS-232 port and power outlet control (on/off) by outlet group.

• Metering

- 1% Metering Accuracy – supports bank-level power metering
- Environment Monitoring – supports external temperature or temperature and humidity sensors for rack temperature and humidity monitoring

• Outlet Switch Control

- Remote and local power outlet control (On/Off, Power Cycle) by individual outlets and outlet groups
- Multiple Power Control Methods – Wake on LAN, System After AC Back, Kill the Power
- Power-On Sequencing – users can set the power-on sequence and delay time for each outlet to allow equipment to be powered on in the correct order to enhance equipment safety
- Proactive Overload Protection (POP) :
 - automatically powers off outlets when current overloads to protect operating devices.
 - Priority Mode enables outlets to be powered off following the outlet shutdown order pre-defined by the administrator via web browser
- Auto Ping – the method pings a device at specified intervals, and if there is no response (request timed out), the PDU automatically powers cycles the outlet (off and then on)
- Holiday Mode – when Holiday Mode is enabled, each outlet will be set to the selection chosen for it: POWER OFF or POWER ON

• [eco DC](#) Energy & DCIM Management Web GUI*

- Automatic discovery of all ATEN PDUs within the same intranet
- Remote real-time power measurement and monitoring of PDUs
- Real-time environment monitoring via sensors
- Plotting and monitoring of all ATEN PDU devices
- Exceed threshold alerts through real-time monitoring, SMTP, and System logs
- Power analysis reports
 - * [eco DC](#) is designed to work with ATEN eco PDUs and is bundled with all PE Series models.

• Features available only on firmware-upgraded models with -ATB part number

- Supports SMTPS, IPv6, Modbus (Over TCP/IP), Auto Ping, TLS1.2, SSH
- Supports IEEE 802.1X
- Authentication: LDAP, TACACS+
- UI – heartbeat, schedule control, mail control, and setting rule

Specifications

Electrical	
Nominal Input Voltage	100 – 120 VAC
Maximum Input Current	15A(Max), 12A(UL de-rated)
Input Frequency	50-60 Hz
Input Connection	For A/J Plug:NEMA 5-15P
Input Power	1800VA(Max),1440VA(UL de-rated)
Outlet Type	Total : 8 x NEMA 5-15R
Nominal Output Voltage	100-120 VAC
Maximum Output Current (Outlet)	NEMA 5-15R : 15A (Max) 12A (UL de-rated)
Maximum Output Current (Bank)	15A (Max) 12A (UL de-rated)
Maximum Output Current (Total)	15A (Max) 12A (UL de-rated)
Metering	Per Bank level Current, Voltage, VA , PF and KWh Monitoring
Outlet Switching	Yes
Environment Sensor Ports	2
Metering Accuracy	Voltage range: 100VAC ~ 250VAC +/-1% Power range: 100W ~ 5000W +/- 2% Current range: 0.1A~1A +/- 0.1A, 1A~20A +/-1%
Communication	
10/100 Mbps	1 x RJ-45
RS-232	1 x DB-9
Switches	
Power	Yes
Environmental	
Temperature (Operating / Storage)	0 – 45°C / -20 – 60°C
Humidity (Operating & Storage)	0–80% RH, Non-Condensing
Physical Properties	
Dimensions (L x W x H)	43.24 x 26.73 x 4.40 cm (17.02 x 10.52 x 1.73 in.)
Weight	3.70 kg (8.15 lb)
Power Cord Length	3 m
Compliance	
EMC Verification	FCC, J55022
Safety Verification	PSE
Note	For some of rack mount products, please note that the standard physical dimensions of WxDxH are expressed using a LxWxH format.

Diagram

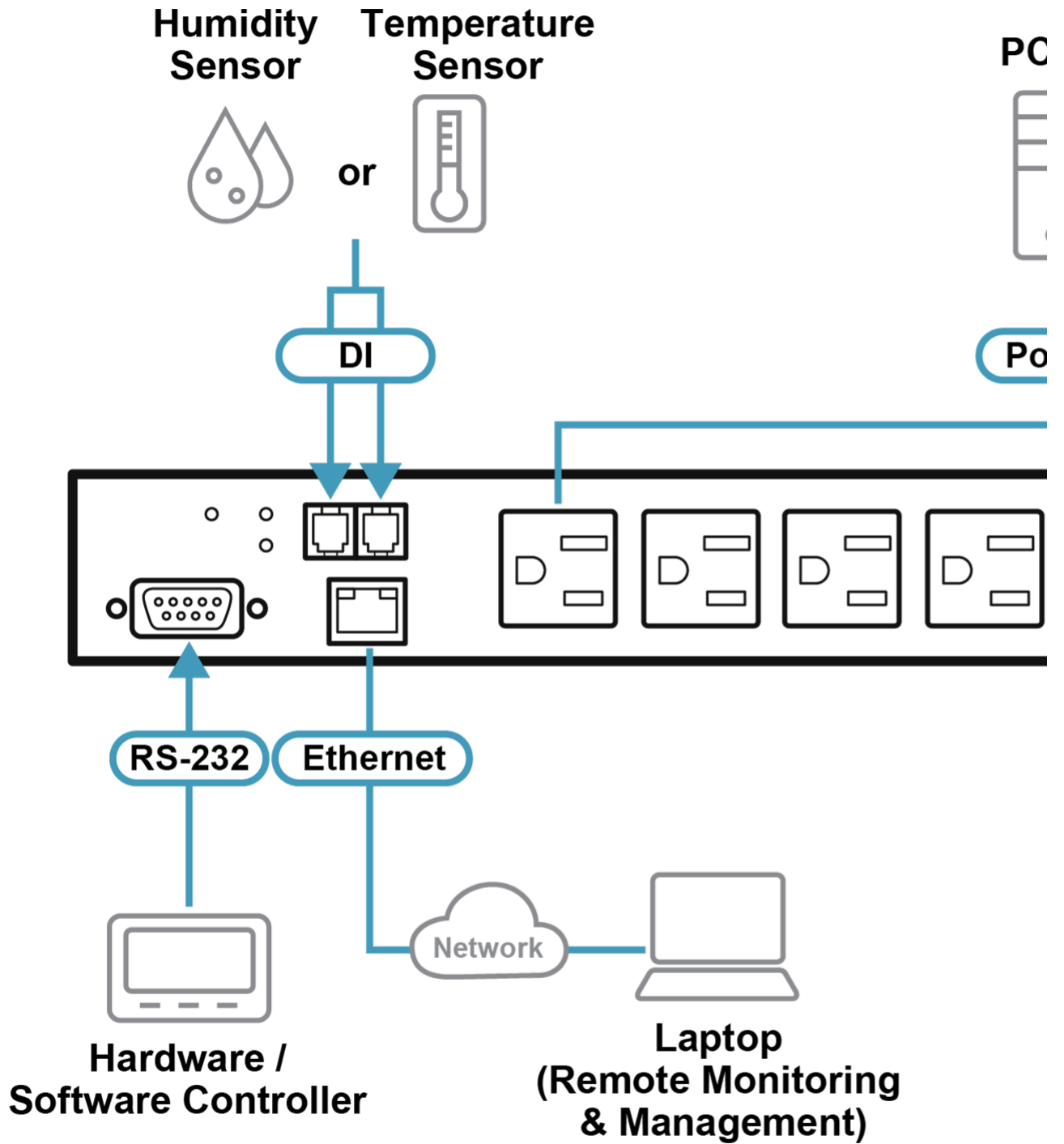



Simply Better Connections

ATEN International Co., Ltd.

3F., No.125, Sec. 2, Datong Rd., Sijhih District., New Taipei City 221, Taiwan
Phone: 886-2-8692-6789 Fax: 886-2-8692-6767
www.aten.com E-mail: marketing@aten.com



© Copyright 2015 ATEN® International Co., Ltd.
ATEN and the ATEN logo are trademarks of ATEN International Co., Ltd.
All rights reserved. All other trademarks are the property of their
respective owners.